



FIMS – Innovative Media Information Management in Digital Workflows





Brad Gilmer
Executive Director
Advanced Media Workflow Association



Hans Hoffmann
EBU Head of Media Production Technologies
SMPTE Engineering Vice President 2011



AGENDA

- What's the problem?
- Requirements
- Commitment
- Work plan
- Outlook and possible standardisation



What problem are
we trying to solve?



Courtesy of:

Ian Wimsett

Senior Technologist

ian.wimsett@redbeemedia.com

www.redbeemedia.com



Red Bee Media

- London, Paris, Berlin, Seville, Sydney
- 129 origination streams
- Each year:
 - 500,000 on-demand assets
 - 132,000 hours of ingest
 - 100,000 hours of closed captioning
 - 500,000 EPG programme listings
 - 6,500 promotional items



File-based workflows circa 2006

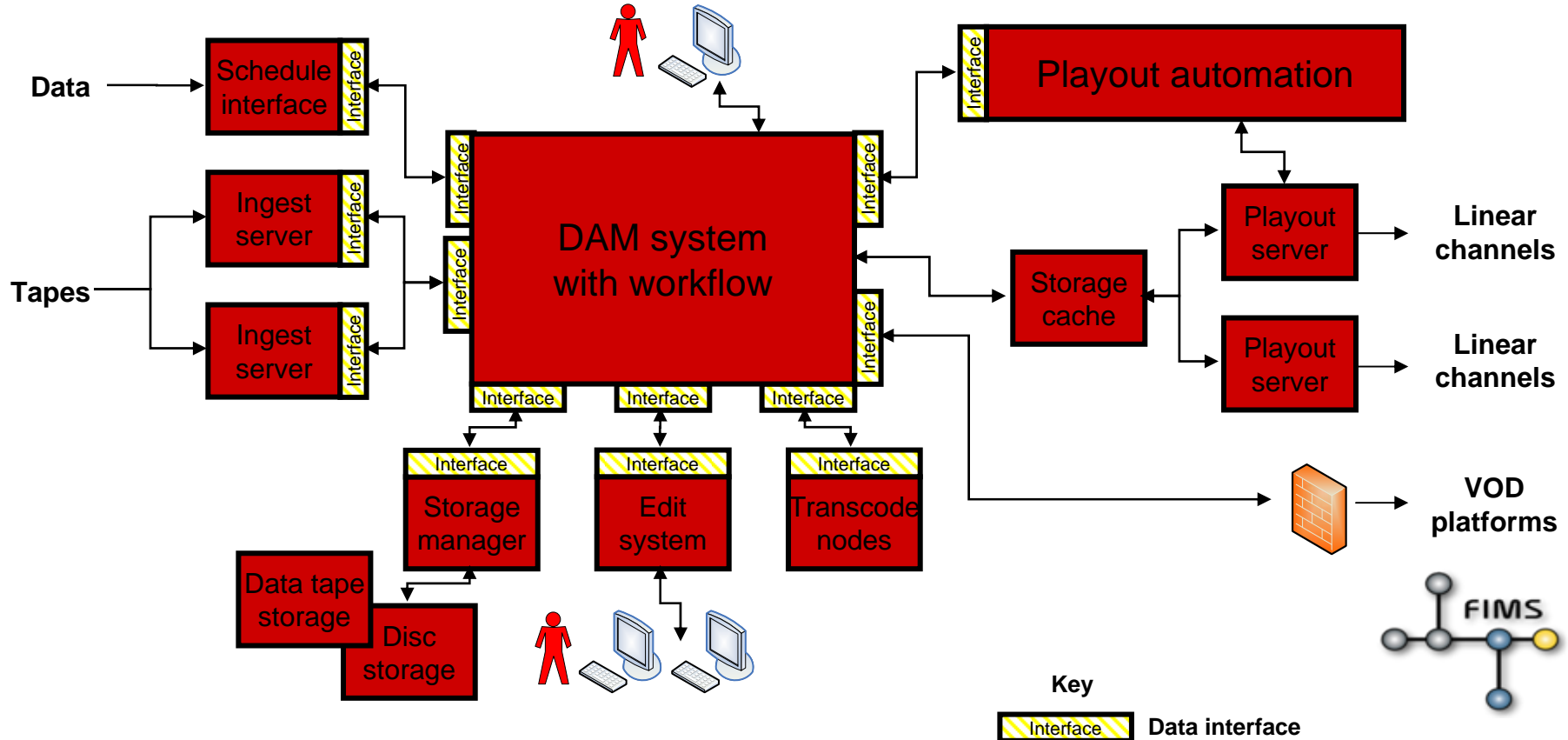

Increased complexity

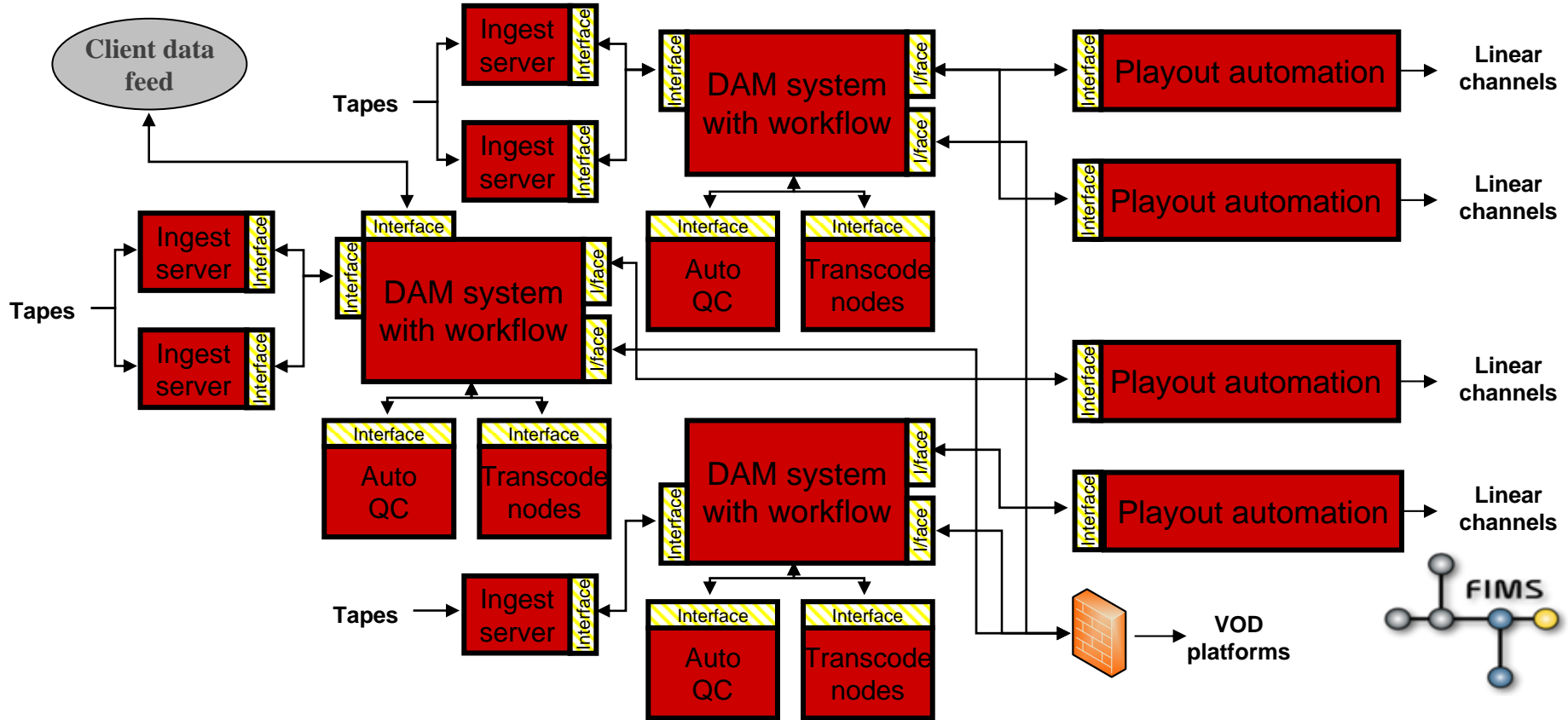

More systems

- **Inefficient duplication**
- **Similar services proliferating**
- **Custom, point-to-point interfaces hard to support**
- **Utilisation not optimum**

What's the alternative?



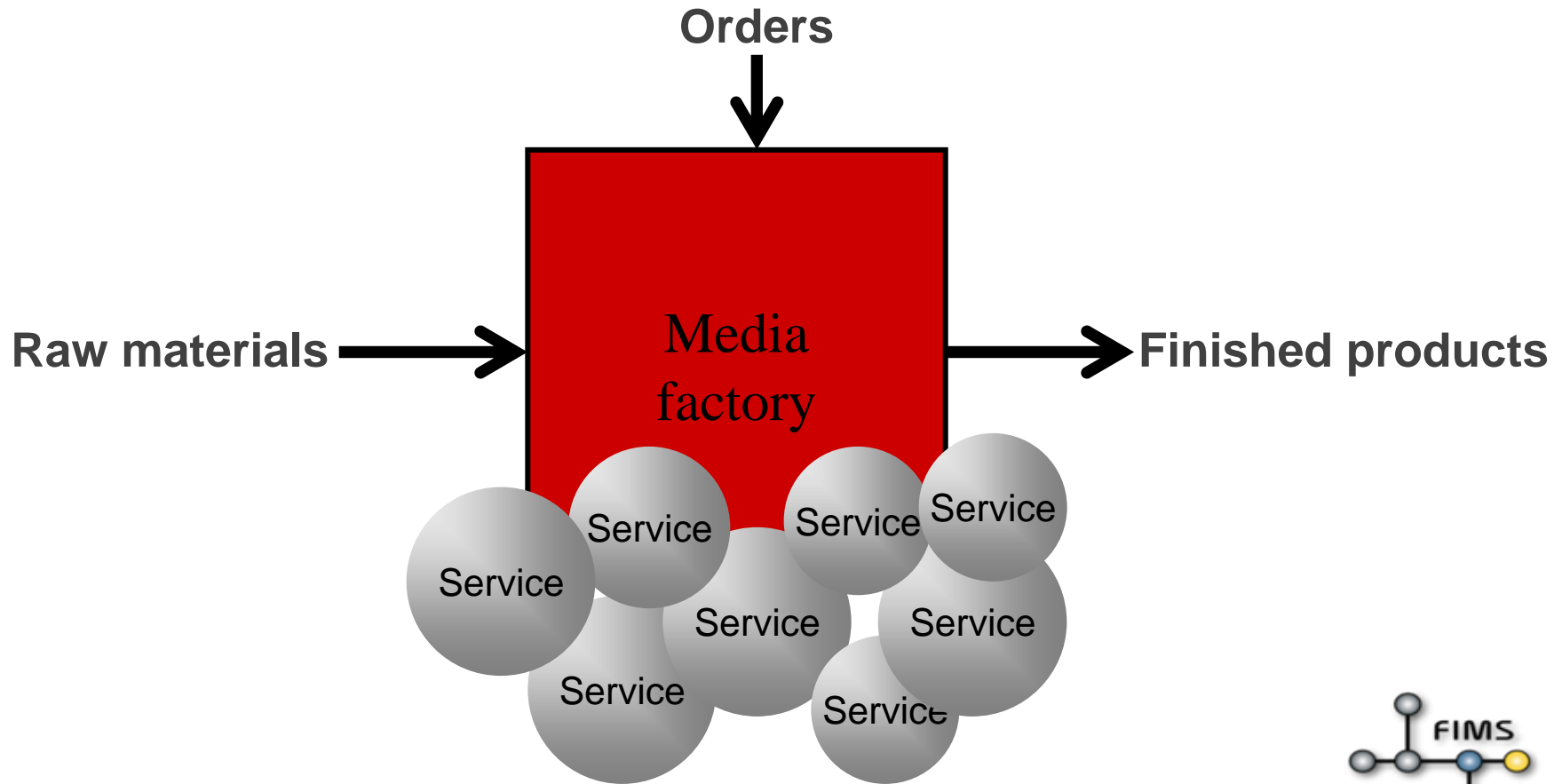

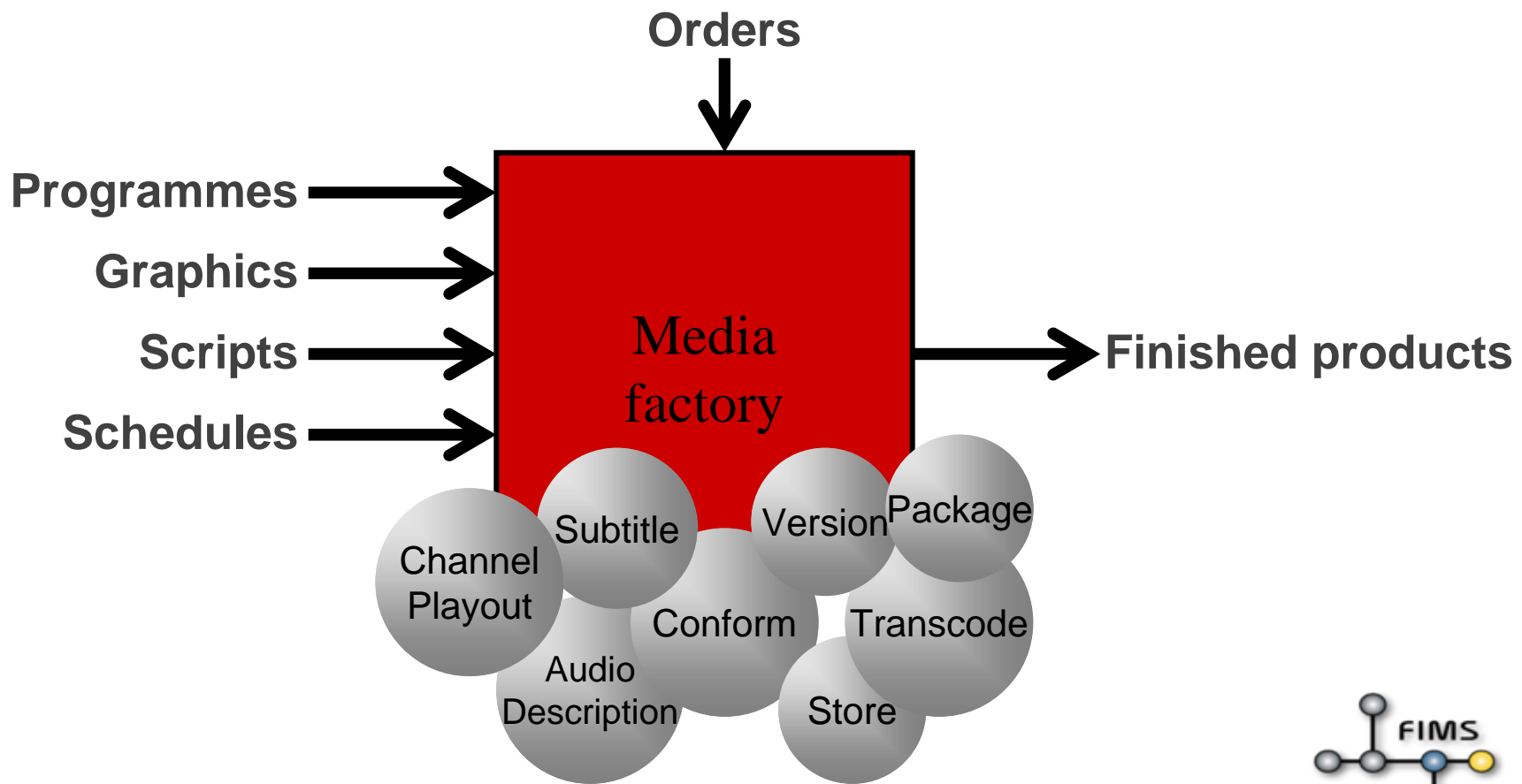

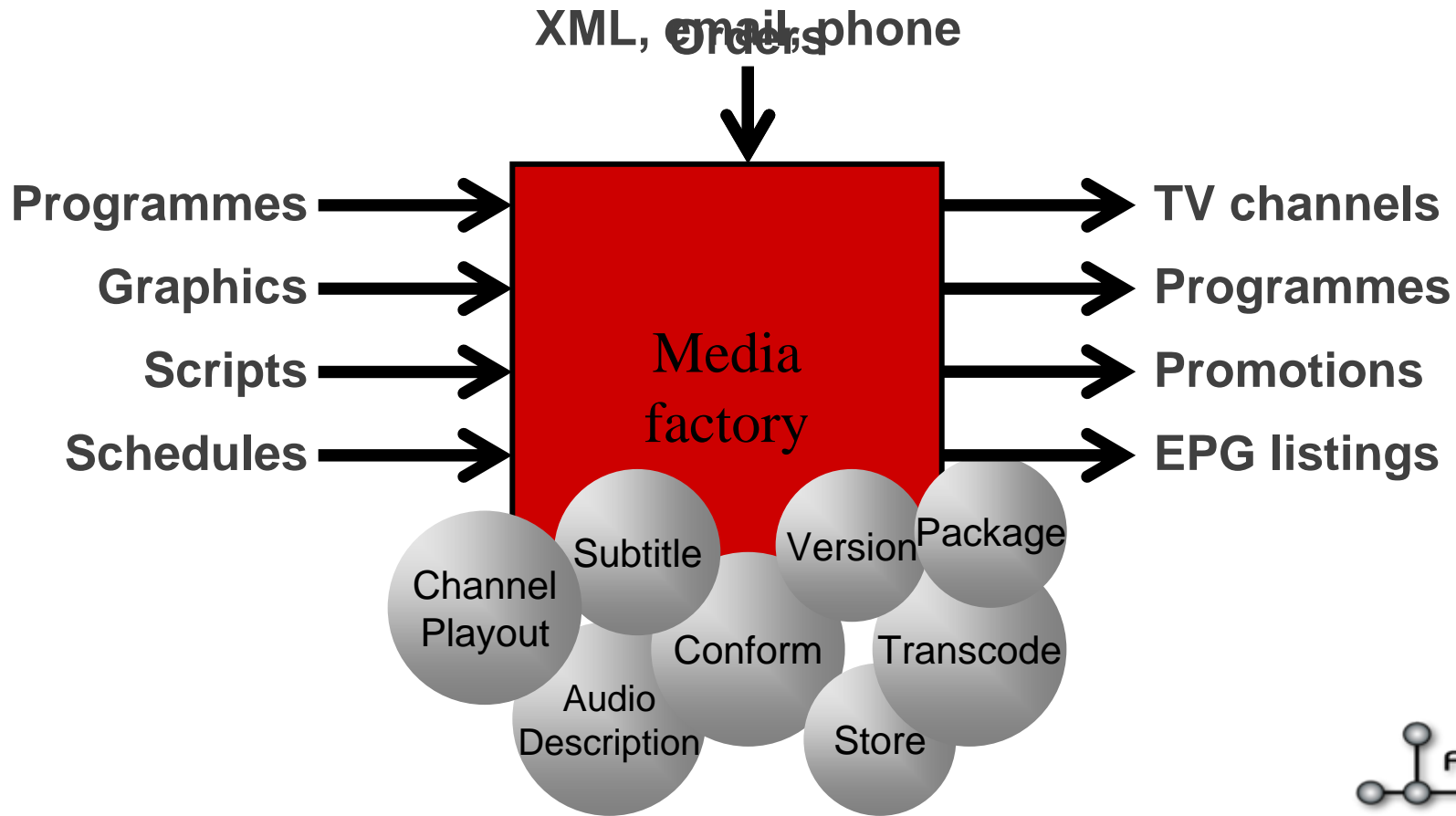

Adapted Services

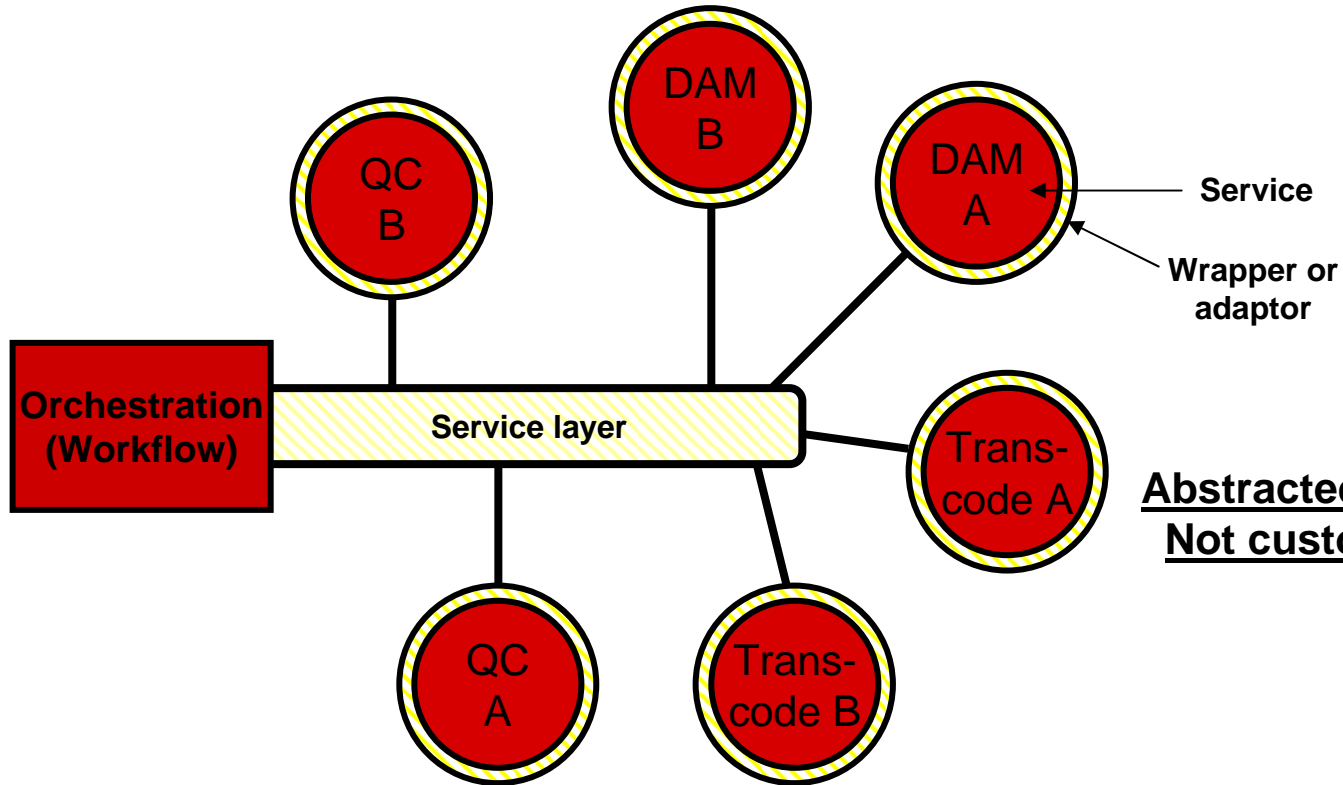

Abstracted services.
Not custom APIs!!



Initial Implementations

- DAM Service
- Client Data Service



Example 1 – DAM service

(Digital Asset management)

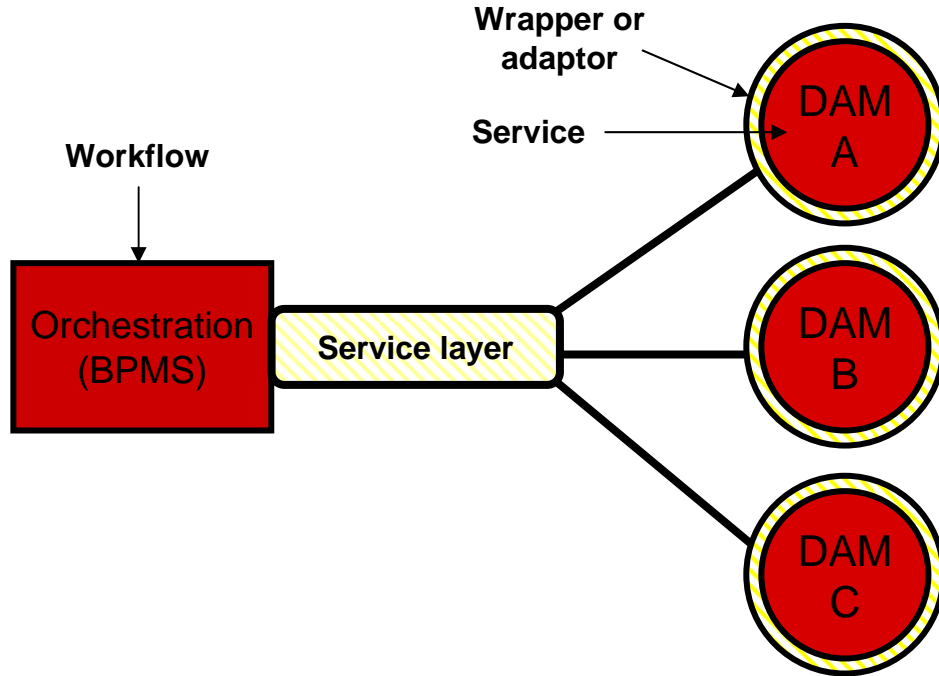

DAM service:

- Create placeholder
- Search assets
- Get asset details
- Export asset
- Import file asset
- Replicate asset to DAM



Example 2 – Client data service

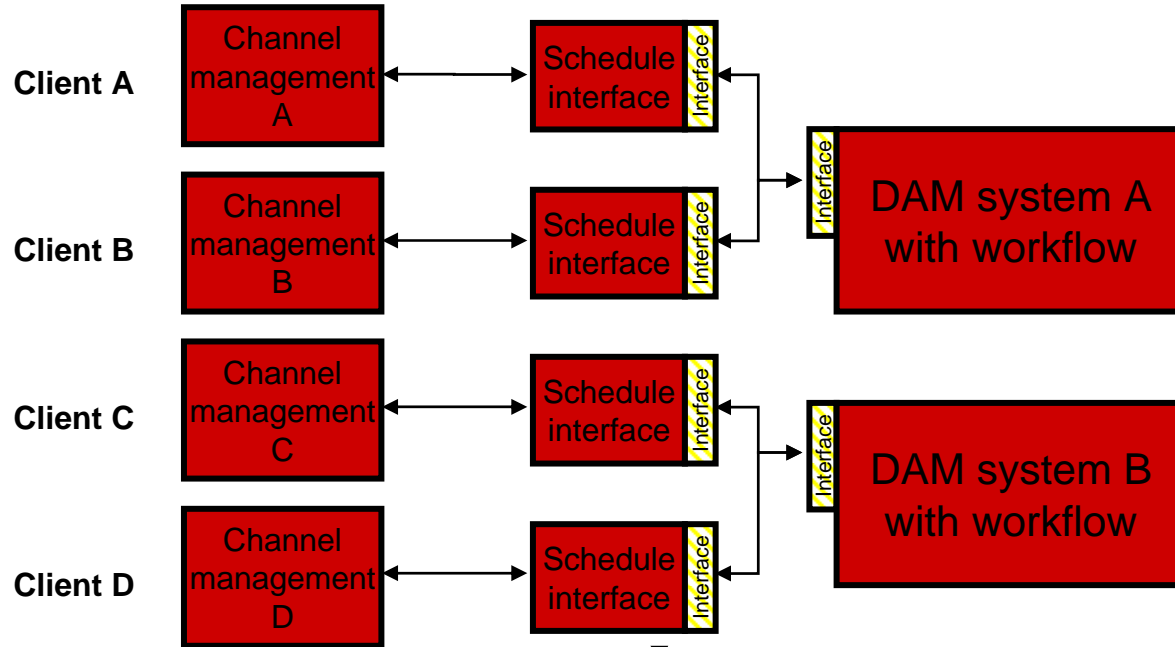

Client metadata -
old method

All interfaces
different



Example 2 – Client data service

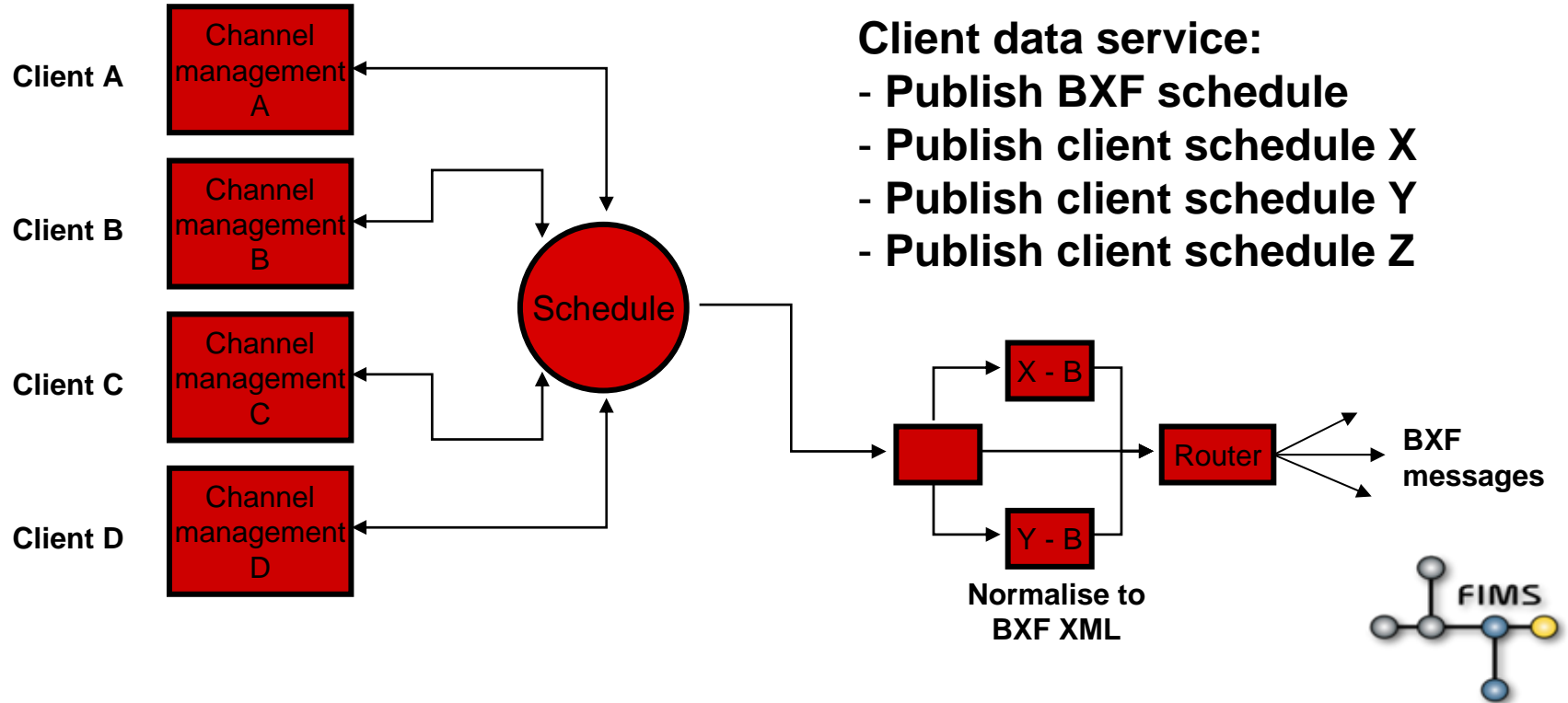

Summary of Challenges For Early Implementers

- **Common service definitions not easy**
- **Proprietary service definitions are proprietary**
- **Custom adaptors need support**
- **Standardized service interfaces are desirable**



FIMS Initiated to Address These Challenges in a Standardized Way



Message from Hans Hoffmann

Why FIMS is Important to Users



EBU and AMWA

- Both organisation started with workflow and process analysis
 - Existing work did not accommodate media industry requirements
 - Combining forces made sense
- Common understandings:
 - To provide an accredited set of standards for interoperable services
 - To be fast, because the window of opportunity to influence industry is short (proprietary systems)
 - To create a reference implementation
 - To be clear on IPR
- Leaders behind FIMS:
 - Giorgio Dimino (RAI), John Footen (ChimeMedia), Brad Gilmer (AMWA), Jean-Pierre Evain (EBU)



Business Requirements

- For FIMS manufacturers
 - Reduce costs
 - Reduce risks associated with integration
 - Concentrate on market differentiation and innovation, not interfaces
- For FIMS users
 - Faster time of integration
 - Lower cost and risk
 - Access to best of breed technology
 - No vendor lock-in
 - Easier cross-media multi-platform delivery
 - Flexibility to adapt workflows to meet new opportunities



Technical Requirements

- For IT
 - Modularity, loose coupling
 - Workflow agility and framework independence
 - Scalability / upgradability / interoperability between vendors
 - Long-term maintenance flexibility (shorter IT innovation lifecycle)
 - Customization: best of breed vs. stove-pipe solution (one doesn't fit all)
- For Media Industry
 - Must support
 - Highly collaborative human workflow
 - Geographically distributed facilities
 - High-bandwidth transfers, SLAs
 - Time synchronization, multiple resolutions



FIMS Request for Technology: phase 1 scope

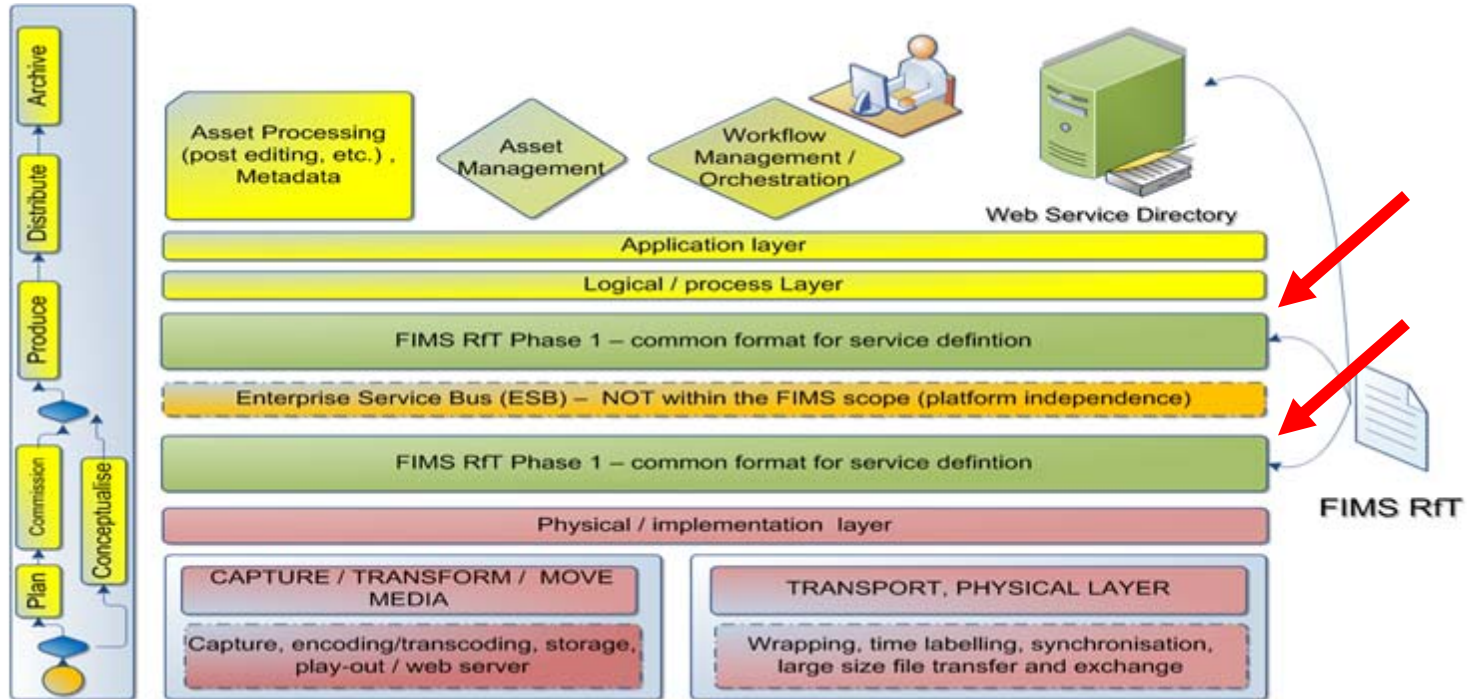

- Phase 1 focuses on the framework
- Define a few services to test framework (e.g. Ingest, Transcode)



Proposed FIMS Framework for standardization

- High Level Architecture

- Reference Architecture
- Definitions

- Media Service Management

- Service lifecycle
- Service behavior

- Media Service Awareness

- Service Registry
- Service level agreements (SLA)

- Media Service Communication

- Service description
- Media Service interface Schemas
- Message format/patterns
- Operations
- Job descriptions

- Media Content Awareness

- Definition of an asset
- Media formats, wrapper adaptation
- Provenance/version

Time awareness

- Scheduling for real-time
- Parallel simultaneous processes (streaming media, ingesting files)

Security and identity

- Service security
- Media security
- Client context

Framework Extensions

- Framework lifecycle
- Taxonomy
- SLA ontology

Implementation bindings

- REST
- WS-*

Phase 2

- More process analysis
- Identification of eligible services



200,000 Foot View of Methodology

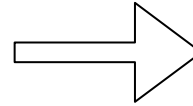
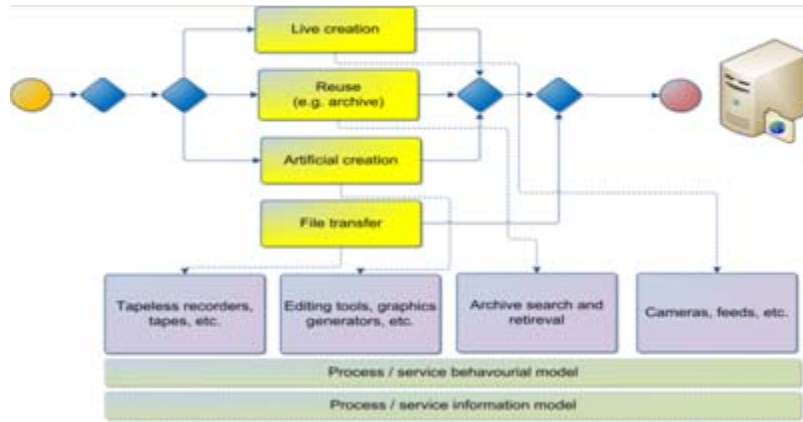

Process Analysis

Web Services, OASIS model

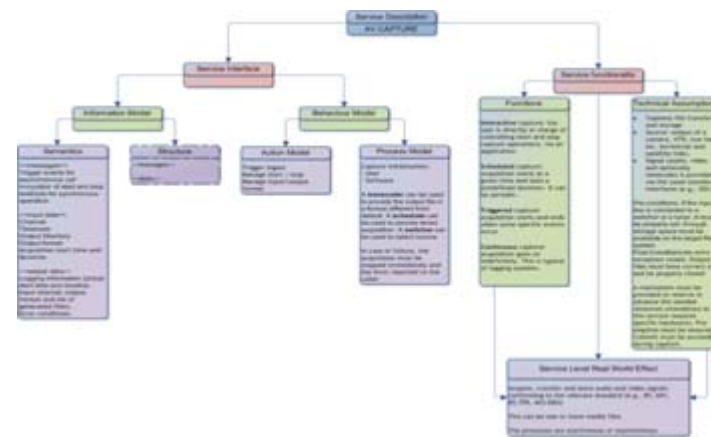
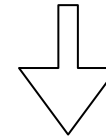

FIMS binding: REST, WS-*

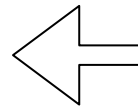

Primary Contributors

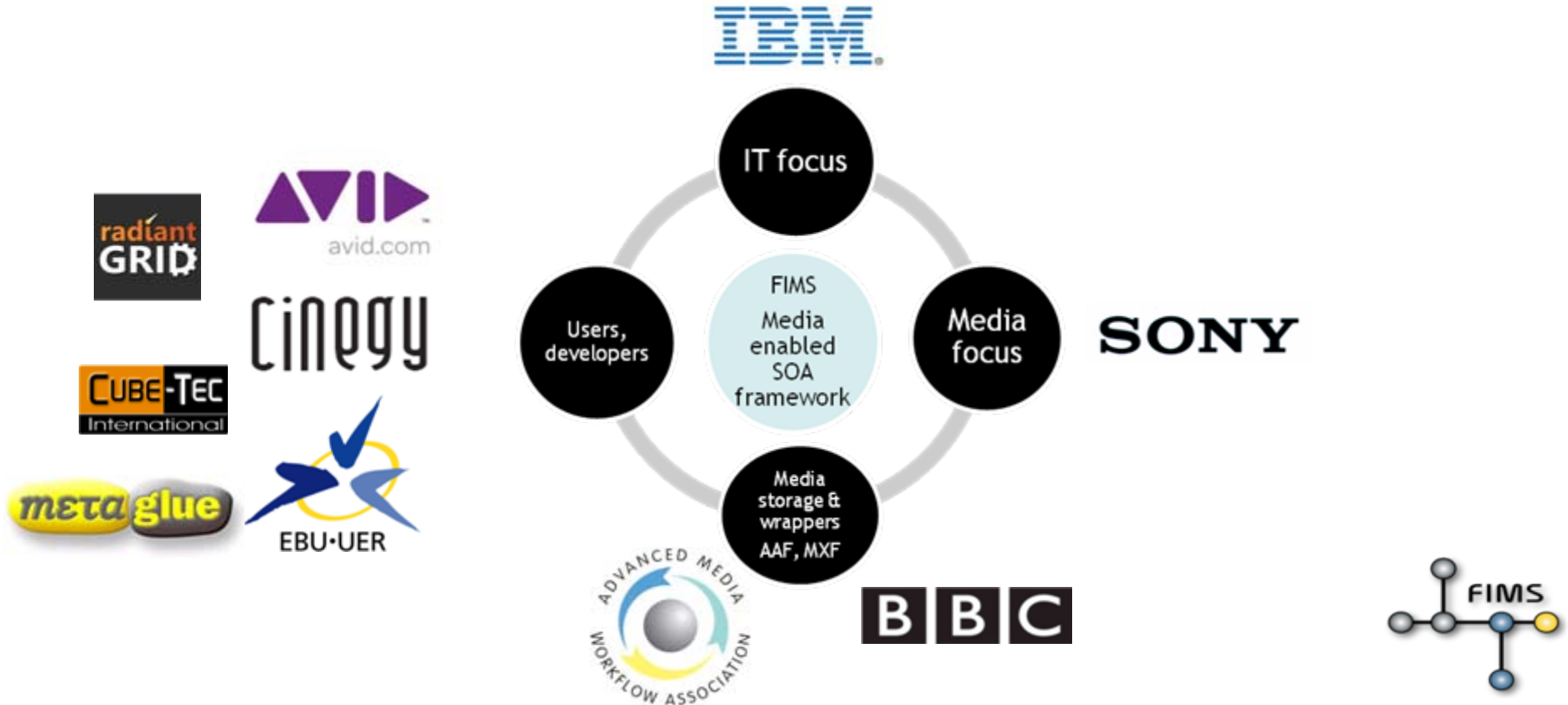

Roadmap

- ✓2010, October 30 – First draft specification
 - Preliminary framework by IBM and Sony
 - Based on the agreed FIMS framework as established in the FIMS RFT
- ✓2010, December 31 – Consolidated specification
 - Taking into account requirements from other users and implementers
 - Avid, BBC, Cinegy, EBU
 - Addressing storage and wrappers
 - AMWA, BBC, EBU
- 2011, February 23 (You Are Here) ←
 - Specification V2.0 available for review
- 2011, April 9-14 – NAB**
 - **FIMS Initial demonstration – North Hall, International Research Park**
- 2011, March 10 – Status report to new SMPTE TC 34 Media Systems, Control and services**
- 2011, June 30 – Final phase 1 specification of the FIMS media SOA framework
- 2011, April-June – RFT2
 - Service specification based on Phase 1 framework



Join FIMS

- All phases of development of the FIMS specification will be public
 - Wiki: <http://wiki.amwa.tv/ebu>
- Take the opportunity to influence FIMS
 - You may still join and contribute even if you didn't respond to the RfT
- Participation is open under the following conditions
 - No need to be an EBU or AMWA member
 - Ruled by the FIMS Participation Agreement terms
 - This applies to contributions in any forms and participation in meetings, webex, etc.
 - FIMS project are governed by AMWA IPR Policy (www.amwa.tv/policies)
 - No license required
 - Compensation-Free Reasonable and Non-Discriminatory License (RAND-Z)
 - Submitters retain IPR rights
 - Implementers gain access to any compensation-free licenses through AMWA Implementers Agreement



Conclusions

- Migration to service-based media workflows is a critical for future success
- A standardized framework and standardized service definitions are critical steps in this effort

Be part of it !



FIMS – Framework for Interoperable Media Services

EBU – AMWA FIMS Framework for interoperable Media Services

**Giorgio Dimino, John Footen, Brad Gilmer, Jean-Pierre
Evain**

RAI, Chime Media, AMWA, EBU

